

220 GPM
< 10 mg/L TDS

FROM R.O. SKID

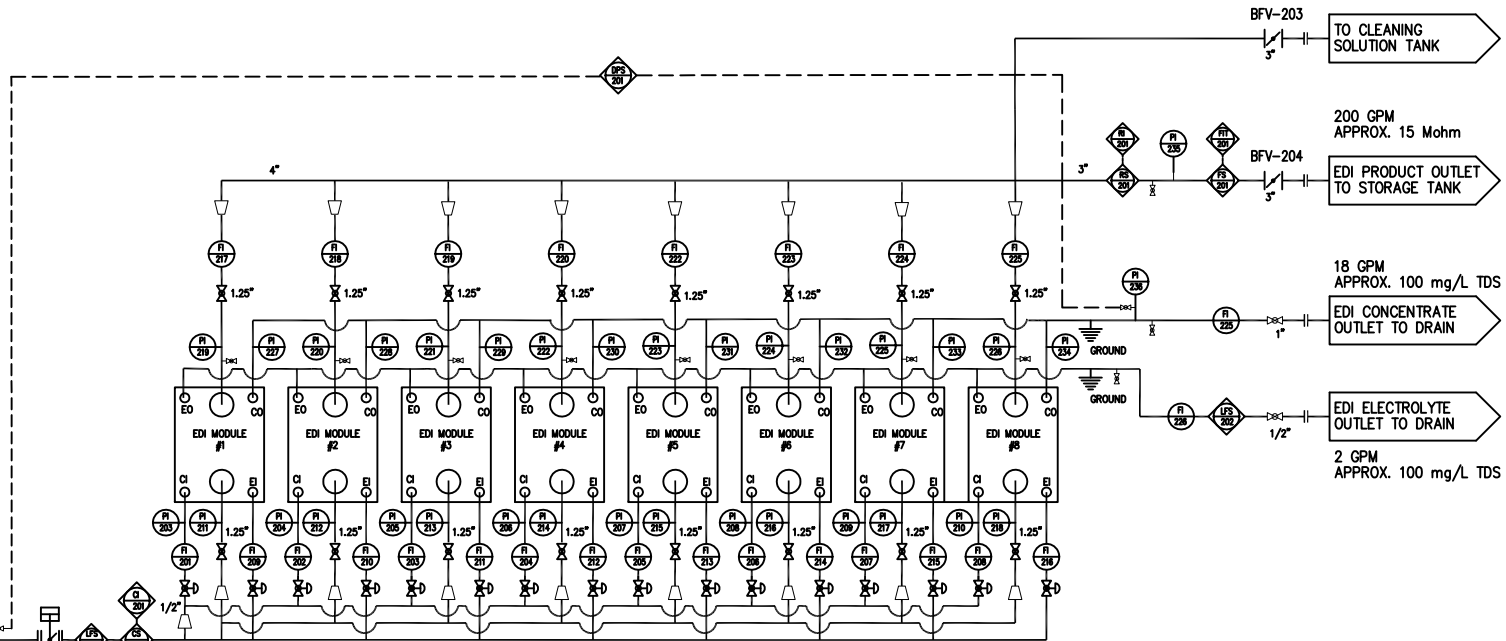
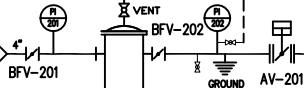
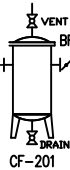

THIS DRAWING IS THE PROPERTY OF AMCO. REPRODUCING OR USING WITHOUT WRITTEN PERMISSION SHALL BE PROHIBITED. CHECK LOCAL OR FEDERAL REGULATIONS FOR USE WITH ANY PURCHASE OTHER THAN THAT FOR WHICH IT IS SPECIFICALLY FURNISHED.

BY		DATE	
DRAWN	EC	08-10-12	
CHECKED	DM		
APPR.	N/A	N/A	
SOLD	WTS		
ENGR.	N/A		

REV	REVISIONS	DATE	BY	CHKD	ENGR.	DATE
0	INITIAL RELEASE TO PRODUCTION	08-12-12	EC	DM		

SHEET 1	DRAWING NO.	REV.
OF 1	11624-01	0

PROCESS & INSTRUMENTATION DIAGRAM
200 GPM ELECTRO-DEIONIZATION SKID